

INDIVIDUAL WASTEWATER TREATMENT

Wastewater treatment plant with a
fixed bed technology



TRICEL

GENERATIONS OF INNOVATION

Tricel® Novo

Simple

Robust

Reliable



www.tricel.fr

Tricel Novo Wastewater Treatment Process

Tricel's wastewater treatment plant is a high quality product with a fixed aerobic bed technology. It guarantees a high treatment performance that doesn't age.

The fixed bed aeration process relies on a three-step treatment process which takes part in three different chambers within the wastewater treatment plant.

1st Stage : Primary Settlement Chamber

The first stage of the wastewater treatment occurs in the primary settlement chamber where the effluents are introduced. The distributed solids and heavy substances drop to the bottom of the plant where they form a sludge. At the same time, a thin layer of scum appears at the surface. The first anaerobic breakdown is being solicited to liquify the sludge slowly but surely.

2nd Stage : The Aeration Chamber

The second stage of the wastewater treatment takes place in the aeration chamber, which involves bacterial support and a specially designed filter media. These bacteria are permanently sustained with air supplied from a purpose-built pump in the unit's top section. As the liquid flows through the filter media, the bacteria feed on the waste and remove it from the liquid.

3rd Stage : Final Settlement Chamber

At this stage, some of the sludge is transported with the liquid into the final settlement chamber. It will then settle to the bottom of the plant where a continuous sludge return system will pump it back to the primary settlement chamber. The remaining treated effluents now meet the required standard to be safely passed out of the Tricel Novo system (which is infiltrated in the soil or rejected safely in a designated area).

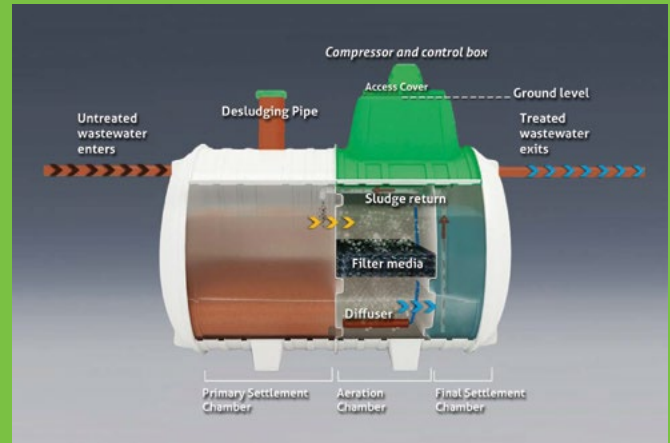

Installation of Tricel Novo FR20



Installation of Tricel Novo FR6



Tricel Novo FR11 installed showing two access covers

Volume/type of Tricel system ⁽¹⁾		Tricel Novo FR6/3000	Tricel Novo FR6/4000	Tricel Novo FR9/5000	Tricel Novo FR9/6000	Tricel Novo FR11/6000	Tricel Novo FR11/7000	Tricel Novo FR14/8000	Tricel Novo FR17/9000	Tricel Novo FR20/10000
French ministerial decree number	Gravity	2011-006-mod01	2012-003-mod01	2011-006-ext01-mod01	2011-006-ext02-mod01	2011-006-ext03-mod01	2011-006-ext04-mod01	2011-006-ext05-mod01	2011-006-ext07-mod01	2011-006-ext09-mod01
	Pumped	2017-004	2017-004-mod01	2017-004-ext01	2017-004-ext02	2017-004-ext03	2017-004-ext04	2017-004-ext05	2017-004-ext07	2017-004-ext09
Treatment capacity and number of inhabitants ⁽²⁾ (number of main rooms according to ministerial decree order 07/03/12)		up to 6 EH/PE ⁽⁶⁾	up to 6 EH/PE	7 - 9 EH/PE	7 - 9 EH/PE	10 - 11 EH/PE	10 - 11 EH/PE	12 - 14 EH/PE	15 - 17 EH/PE	18 - 20 EH/PE
Hydraulic load ⁽²⁾	l/day	150 - 900	150 - 900	1050 - 1350	1050 - 1350	1500 - 1650	1500 - 1650	1800 - 2100	2250 - 2550	2700 - 3000
Organic Load ⁽²⁾	DBO ₅ kg/d	0,06 - 0,36	0,06 - 0,36	0,42 - 0,54	0,42 - 0,54	0,60 - 0,66	0,60 - 0,66	0,72 - 0,84	0,90 - 1,02	1,08 - 1,20
Total Volume	l	3000	4000	4731	5546	5546	7176	7176	8806	10436
Primary chamber capacity	l	1400	2400	2408	3223	2488	4118	3311	4183	5250
Aeration chamber capacity	l	900	900	1377	1377	1695	1695	2249	2755	3081
Final settlement chamber capacity	l	700	700	946	946	1363	1363	1616	1868	2105
Total length (A)	cm	210	260	310	360	360	460	460	560	660
Total width (B)	cm	164	164	164	164	164	164	164	164	164
Total height (C)	cm	224	224	224	224	227	227	227	227	227
Inlet invert to base (D)	cm	137,5	137,5	137,5	137,5	137,5	137,5	137,5	137,5	137,5
Outlet invert to base (E) (Gravity/Pump)	cm	130 / 158.5	130 / 158.5	130 / 158.5	130 / 158.5	130 / 158.5	130 / 158.5	130 / 158.5	130 / 158.5	130 / 158.5
Inlet invert to ground level (F)	cm	53,5	53,5	53,5	53,5	53,5	53,5	53,5	53,5	53,5
Outlet invert to ground level (G) ⁽⁴⁾ / (P) ⁽⁵⁾	cm	61/25	61/25	61/25	61/25	61/25	61/25	61/25	61/25	61/25
Height difference between inlet/outlet ⁽⁴⁾	cm	7,5	7,5	7,5	7,5	7,5	7,5	7,5	7,5	7,5
Height above ground level (H)	cm	33	33	33	33	36	36	36	36	36
Inlet / outlet diameter (Gravity/Pump)	mm	100 / 40	100 / 40	100 / 40	100 / 40	100 / 40	100 / 40	100 / 40	100 / 40	100 / 40
Number of access covers/risers	units	1	1	1	1	2	2	3	4	4
Weight empty ⁽³⁾	kg	275	300	375	400	400	500	500	600	700

Tricel Novo with gravity discharge

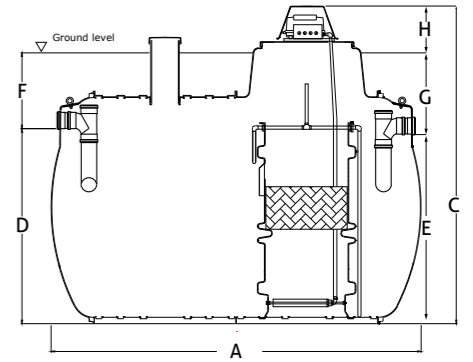

Tricel Novo with integrated pump discharge

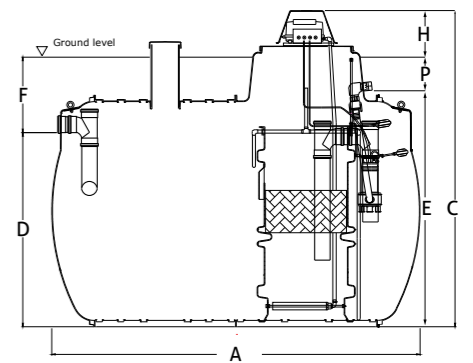

**Ministerial
decree numbers
from 1 to 20 EH/PE**

(1) Above 21 EH/PE ("light commercial" or "grouped" wastewater treatment system range), please contact us.

(2) It should be noted that a system designed for x to y EH/PE will work perfectly with an actual number of users lower than this EH/PE number (e.g. an FR14/8000, designed for 12 to 14 EH/PE, will work effectively too for 7 or 10 actual users).

(3) Add 100 kg for lifting purposes.

(4) For Tricel Novo gravity

(5) For Tricel Novo pumped

(6) For three inhabitants max



Why choose Tricel?

Markings and Certifications

- French "Agrément ministériel" approval for Tricel® 1 to 20 PE (population equivalent) as published in the Journal Officiel on the 22nd April 2011, 17th March 2012, 3rd January 2013, 15th August 2017 and 28th April 2019
- Conforms to the ministerial order "technical specifications" of 7th September 2009 and as modified by the 7th March 2012 order
- Tricel is CE marked from 1 to 50PE after undergoing 38 weeks of stringent testing to conform to EN 12566-3, carried out in PIA in Aix-la-Chapelle in Germany. This demonstrates constant high-quality treatment from the Tricel system

Installation

- Ideal for new builds, especially in cases of limited space as well as for renovations: Tricel is a compact system with a footprint (site coverage) of less than 5m² for 6 PE and less than 11m² for 20 PE (to be compared with the 40 to 200m² of a traditional installation).
- Lightweight, single tank easy to transport and handle.
- The Tricel system is delivered ready to install for an easy and fast installation, with minimal site adjustment reducing the risk of on-site error.
- Extremely robust GRP tank moulded by heat compression: backfilled with sand or gravel (crushed 4/10 or rounded 4/16), 75cm backfill allowed above the crown of the tank, resistant to groundwater.
- Small excavation depth, high-level inlet and outlet to avoid deep trenches, with a height difference of 7.5cm only between the inlet and outlet.
- A secondary vent is integrated directly into the de-sludge manhole cover.
- Manhole risers available in 25cm, 50cm and 75cm.
- Tricel systems are also available with an integrated submerged pump which removes the need for a pump station.

The Result

- Underground installation is carried out for minimal interference with the surrounding landscape.
- Electro-mechanical equipment installed on the tank (as standard) or remote-located if required.
- Extremely quiet whilst in operation with no odour.
- Low running costs.
- Exceptional feature: in applications of restricted access or limited space it may be possible to assemble a Tricel system directly on location. Subject to a mandatory survey by Tricel to verify the feasibility of the assembly.

Maintenance

- Extremely reliable, with a strong simple design and high-quality components (ceramic quartz diffusers without membranes which do not get clogged, Medo air blowers without diaphragms etc.).
- We have designed our systems with few electro-mechanical components and no electronic components which ensures little or no breakdown risk as demonstrated by our 18 years of experience and 35,000 Tricel Novo wastewater treatment plant installations.
- No electro-mechanical part inside the tank avoiding the risk of corrosion.
- Naturally forming and continually multiplying biomass on a fixed film, utilises a trickling filter and sludge return process to maintain performance during periods of under loading and non-use.
- Excellent performance in overloading conditions.
- No system adjustment regardless of influent levels • Low maintenance for customer peace of mind and minimal maintenance costs.
- Annual maintenance contracts available from Tricel's network of exclusive Partners.
- Permanent and lifelong solution: the PVC "honeycomb" bacteria bed does not block or deteriorate over time.
- Visual and acoustic alarm as standard.
- All components visible, accessible and easy to remove if needed.
- Easy de-sludging of the primary settlement chamber through the de-sludge manhole.
- De-sludging frequency of 1 to 4 years (depending on model type) observed in real use conditions at full loading. De-sludging, which only concerns the primary settlement chamber, is less frequent when the wastewater treatment system functions at reduced load; e.g., an FR6/4000 (sized for 1 to 6 PE) with 3 permanent users requires an average de-sludge rate of 4 to 7 years.

Quality Assurance

- Tricel wastewater treatment system traceability and tracking ensured by Tricel France and its network of exclusive Partners.
- Manufactured in France for greater proximity to our customers, ensuring a localised customer service.
- 20 years guarantee on the GRP structure and 2 years on the electro-mechanical components.

The Tricel Group is a global provider for high-quality solutions for water, environment, construction and industrial distribution. For over 45 years, our company ethos of "Generations of Innovation" is built around three interlinking themes; Innovation, Quality and Heritage. We manufacture and deliver products with advanced technology that our customers believe in. We are physically present in 5 different countries, which allows us to make a difference in terms of the capacity of production, versatility and adaptability. We also offer a complete range of systems in more than 50 countries throughout the world.

Tricel France is :

The first manufacturer of a wastewater treatment plant in France.

Two factories with dedicated technical services and a head office based near Poitiers, for greater **proximity to our customers and reactive customer service**.

A quality-orientated philosophy offering what is probably the best value for money to our customers: all of our equipment is **robust and of high quality**, the water tightness of every single tank (not based on random samplings) is tested at the end of the production process, traceability is ensured on all of our wastewater treatment systems...

... for flawless **reliability** and absolute **peace of mind**.

A **network of exclusive distribution Partners, that are specialists in wastewater treatment systems** (see the list on our website), who ensure specifications and sales as well as the start-up, maintenance and after-sales service on each Tricel wastewater treatment system installed.

Networks of installers selected by our Partners in their respective sectors to ensure the perfect installation of your wastewater treatment system.

Extensive experience in wastewater treatment system with over 35,000 Tricel wastewater treatment systems installed across the world in all types of and under all climates.



French Ministerial Decree
1 to 6-9-11-14-17-20 EH/PE
n° 2011-006 & ext.
n° 2012-003
n° 2017-004 & ext.



For more information or to **get a Quote**, please reach out to your **exclusive Tricel Partner**:

Or contact us at 05 17 03 00 00 (Monday to Friday 8:30 to 5:30 pm) or on our website www.tricel.fr/contact